

275C Series

600lbs Electromagnetic Lock

Model UL275C-S (Unmonitored Version)
UL275C-SP (LED with indicating lamp only)

DESCRIPTION

C-Series 600lbs EM Locks were designed to meet fire/life safety applications by providing an auxiliary locking mechanism that has no moving parts to bind or wear out for trouble free operation. This will ensure inhibited release at all times where they have become extremely prevalent in applications other than fire/life safety. Suitable for access controlled & secure areas within buildings.

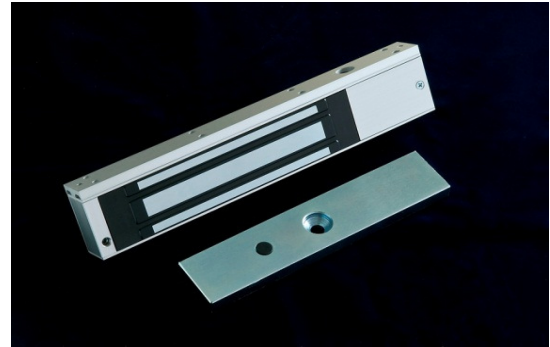

FEATURES & SPECIFICATION



Life Safety Applications



Zero Residual Magnetism



Low Energy Consumption



Cost Savings

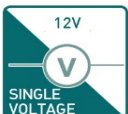

12Vdc



Ideal for all door types

Models	UL275C-S	UL275C-SP
Features & Spec.		
Lock Status Monitoring	-	-
Indication Lamp	-	LED
Holding Force	Up to 600lbs	
Magnet Size	250 X 42 X 26 mm	
Armature Size	180 X 38 X 11 mm	
Current Drain	500mA±10%/12Vdc	
Operating Temperature	(-10 to 55) °C (14 to 131) °F	
Housing Finishing	Anodized Aluminium	
Est. Weight	2.0kg	

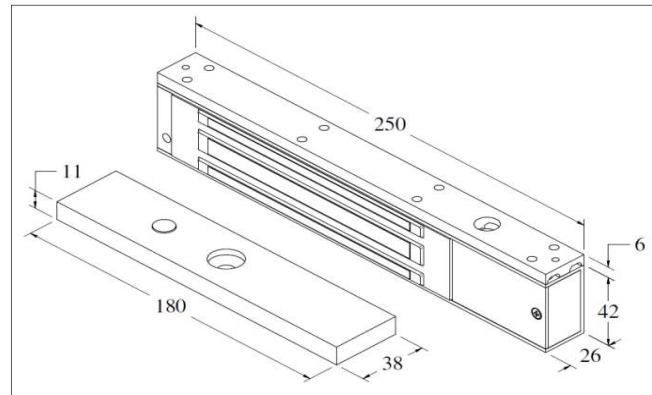

275C Series

600lbs Electromagnetic Lock

STANDARD INSTALLATION DIAGRAM

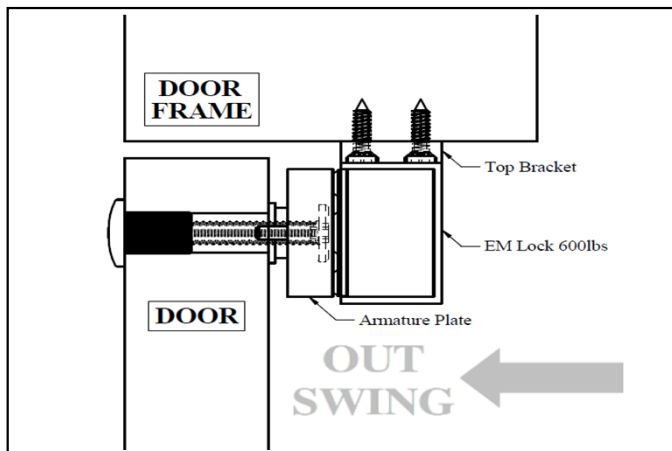
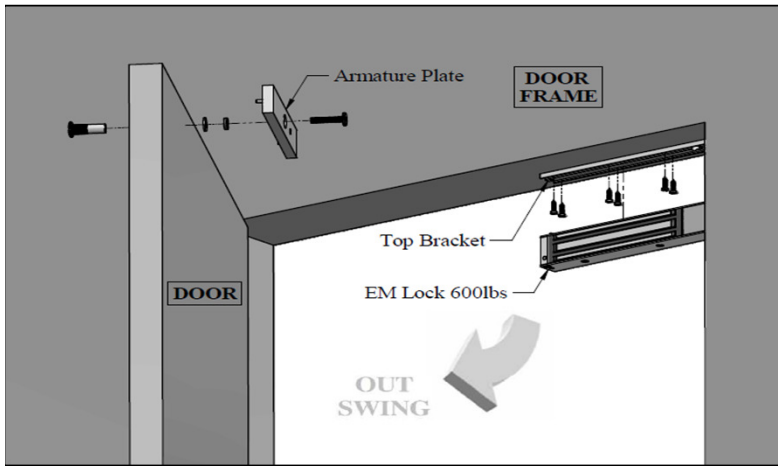

OPTIONAL - BRACKET SELECTION

U1-275	ZL-275	ZLE-275	LS-275	GG-275	ZLC-275
ZLC-275-G	ZLDC-275-G	LSDC-275-G	AH-275	AB-275	

Type your text