



Hotel Lock

HL 100



HL-100 Electronic Hotel Lock- RFID Based

eSSL provides the latest Radio Frequency Identification technology with typical outline design. Lock is specifically designed for those people who are looking for better quality products with competitive price.



RFID Specifications

13.56MHz technology Compatible with the following standard: ISO 14443 A (MIFARE Classic) Eleven free sectors for future All-in-one card application use

HL100 Features

- ❖ Standalone electronic lock with RFID technology.
- ❖ High security stainless steel mortise lock case available in ANSI, AUS and EURO versions.
- ❖ Stainless steel handle with high strength central spindle. 3-point stainless steel latch construction with antifriction mechanism.
- ❖ Mortise equipped 20mm throw high strength deadbolt.
- ❖ Panic release function - the deadbolt & latch are automatically retracted by inside handle for easy regress in emergency situation.
- ❖ ADA compliant (guest with physical disabilities).
- ❖ Future proof re-programmable FLASH RAM lock memory.
- ❖ Powered by four AA batteries that provide up to 1 year normal life time.
- ❖ 414 events audit trail.
- ❖ Compatible with BIS HOTEL software platform.
- ❖ High security mechanical override cylinder available.
- ❖ Compatible hotel function and residential function.

Advantage

- ❖ **More Guest Satisfaction:** Worldwide famous Mifare contactless technology for all guest and staff cards. No need to insert keycard, easier to access guest room.
- ❖ **More Security:** Anti-hacker technology for locks. Unlike other competitor's keycards can be hacked into lock memory through mini USB port on outside escutcheon, crack and open the keycards. Be-Tech anti-hacker technology not allows re-program FLASH RAM lock memory from outside escutcheon.
- ❖ **More Adaptability:** RFID keycards and carriers can be used for any style hotels, you can choose from low cost guest card, wristbands and key fobs to perfectly match different hotel type: Business, Resort, Spa, All-Inclusive.
- ❖ **More Information and Control:** BASE electronic lock can check information on handheld Service Terminal for better information and management: Entry record audit trail, low battery status, real-time clock adjustment, etc...
- ❖ **More Integration:** You can integrate and interface BASE RFID keycards with other applications at your hotel.
- ❖ **More Exclusivity:** Provide a new experience for your customers and enhance the image of your hotel.
- ❖ **More Productiveness:** Provides Tour Group Reservation and Tour Group Check-in, enhance the check-in efficiency of your hotel....
- ❖ **and Less Expense:** BASE RFID by eSSL is selling at a very competitive price by eSSL Distributors & Dealers.



HL100

- ❖ Power: 4no of AA Alkaline Batteries
- ❖ Battery Location: Inside of the back lock
- ❖ Material: Handles, Lock Body made of Stainless Steel SS304
- ❖ Emergency Opening: Mechanical Key
- ❖ Locking Mechanism: Electro Mechanical Locking Mechanism
- ❖ Door Thickness: 35-80mm
- ❖ System Software: BIS Hotel
- ❖ Storage Temperature : -20°C~ 60°C
- ❖ RFID Standard: ISO 14443A (Mifare Classic)

HL100 Dimensions

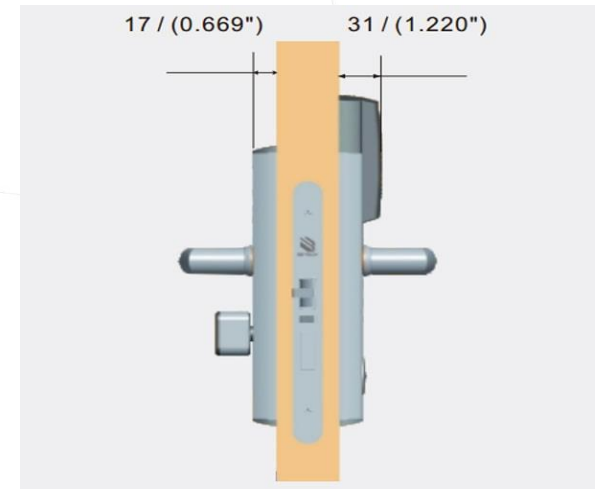
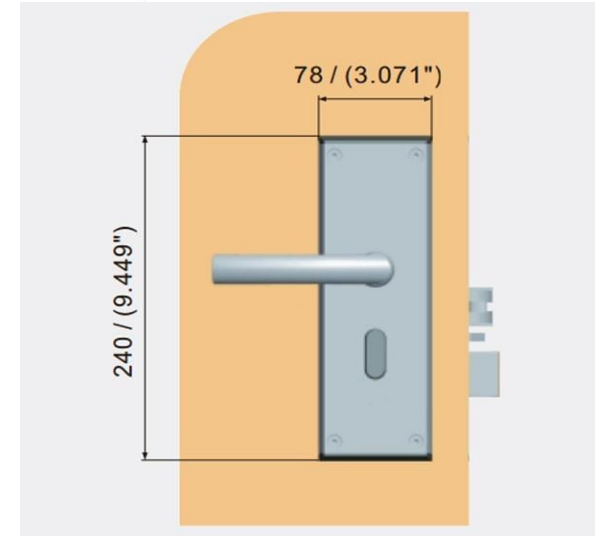
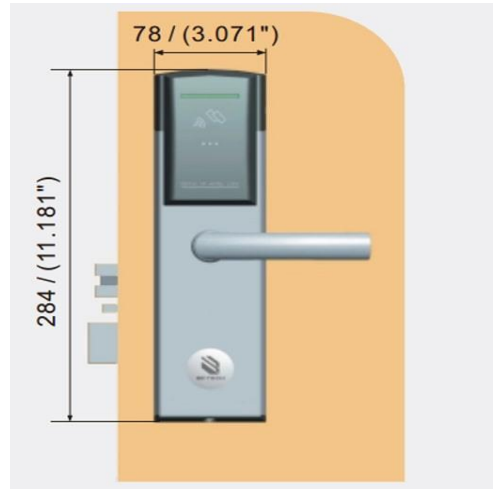

Hotel Lock Software



BIS HOTEL is a full-featured, functionally rich intelligent system with the power, flexibility and convenience to satisfy the needs of any hotel. Beside the basic requirement found in most locking system, the BIS HOTEL also includes various features enabling you to achieve All-in-one card security management, tour group check-in and shift-to-shift operations.

Hand Held Service Unit



HL-100 - Hand Held Service Unit

Reliable and convenient handheld service unit is necessary for uploading programs and data transfer to electronic door locks & safes. This handheld service unit will synchronizes programming between the PC to the locks.

- ❖ Dimensions(L x W x D): 155 x 80 x 28 mm (6.1 x 3.15 x 1.1 inch)
- ❖ Voltage: 6V DC Battery capacity: Minimum operating time: 15 hours
- ❖ Minimum standby time: 90 hours
- ❖ Type of batteries: 4 AA alkaline batteries - 1,5V
- ❖ Operation temperature: -10°C to 60°C
- ❖ Storage temperature: -30°C to 75°C
- ❖ Humidity resistance: 20% to 95% non-condensing
- ❖ Connector: USB type B

RFID Card Encoder



HL100-RFID Card Encoder

Encoders is used for reading & writing cards that sync the data into the card which are given to guest to access the hotel room.

Hotel Lock System Configuration

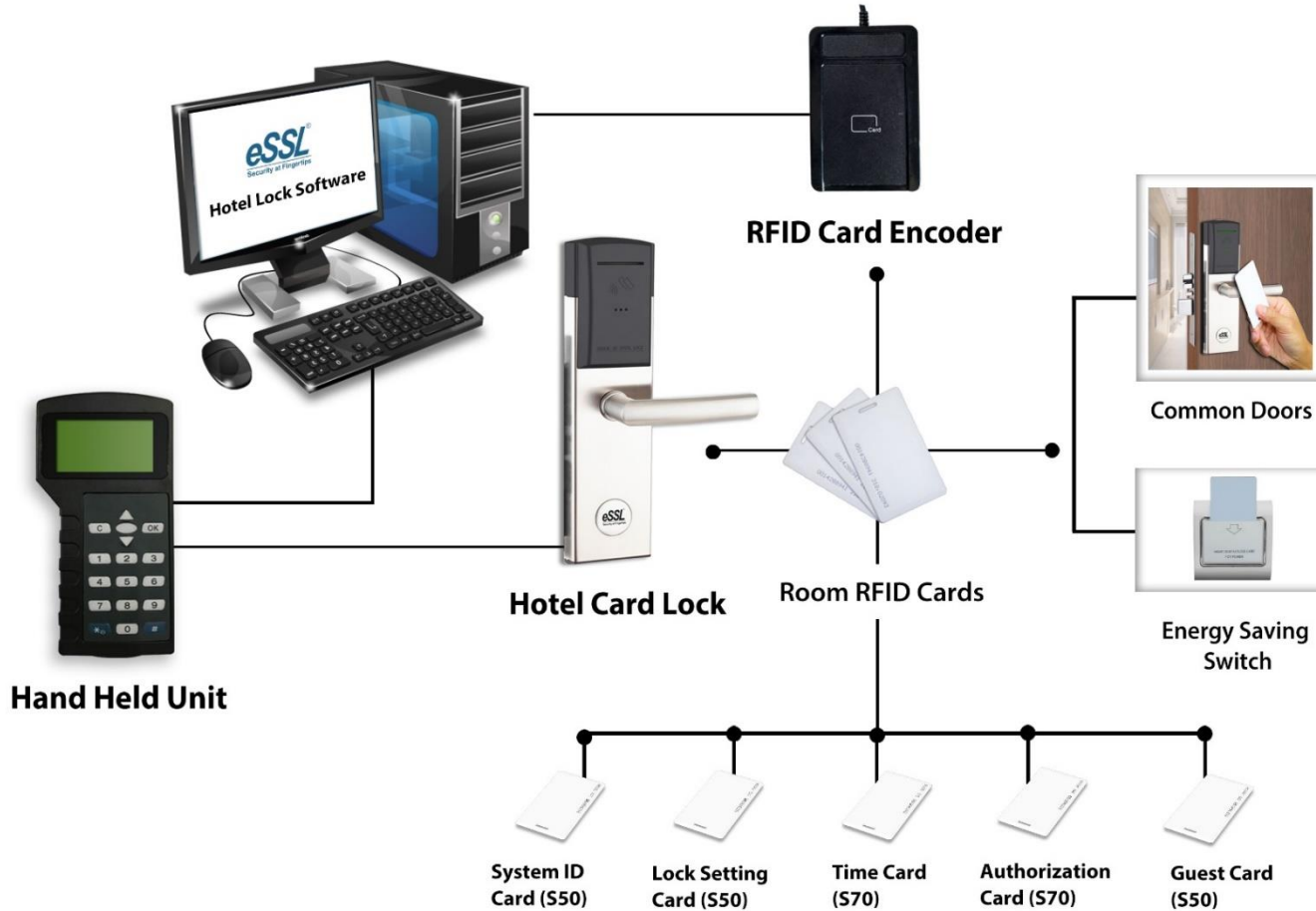



*Thank
you*

info@ampletrails.com

+91-9315441078



For Your Time & Attention